

Illuminator EM

Emergency Lighting Inverter System

Single Phase Systems 1.0KVA/KW to 2.8KVA/KW
Available to Ship Within 5 Days



Same size footprint for every model!

EM-1 | 1000 VA/W

EM-2 | 1600 VA/W
EM-3 | 2200 VA/W

EM-4 | 2800 VA/W

STANDARD FEATURES

- 98% Efficient (Typical)
- 65KAIC Input Rating
- NFPA 101 Self Testing and Data Logging
- User Programmable with Password Protection
- UL 924 Listed
- Automatic Event, Test and Alarm Log
- Compatible with all lighting loads including HID/LED
- Input Circuit Breaker
- One Output Circuit Breaker
- 90 Minute Run Time
- No Break 2ms Transfer Time
- Wall Hung Units (No Mounting Brackets)

OPTIONAL FEATURES

- Enhanced Communications
 - Expanded Building Management Protocols
 - BACnet or Modbus Communications Interface
 - NEW IoT Connect Cloud Software**
- Internal or External Maintenance Bypass
- Summary Form C Contacts
- Status Monitoring Contacts
- Output Circuit Breakers
- Normally Off Output with Variable Time Delay
- Output Trip Alarms
- Remote Summary Alarm Panel
- Wall Brackets, Floor, or Seismic Mounting
- Extended Factory Warranty, Factory Startup and Training

SPECIFICATIONS

- Input Voltage: 120 or 277VAC 1 Phase 2 Wire Plus Ground*
- Output Voltage: 120 or 277VAC 1 Phase 2 Wire Plus Ground*
- Output Load Power Factor .5 Lag to .5 Lead
- Output Distortion Less than 3% THD for Linear Loads
- Forced Air Cooling Only During Emergency Operation; No Filters Required

- Electronic and Magnetic Ballast Compatible
- Generator Compatibility
- Custom Voltages Available
- 90 Minute Run Time Standard

*Other Voltages Available

ORDERING GUIDE

Example Model Number:
1-EM-4-S-BA2007-T-S-M-2YW

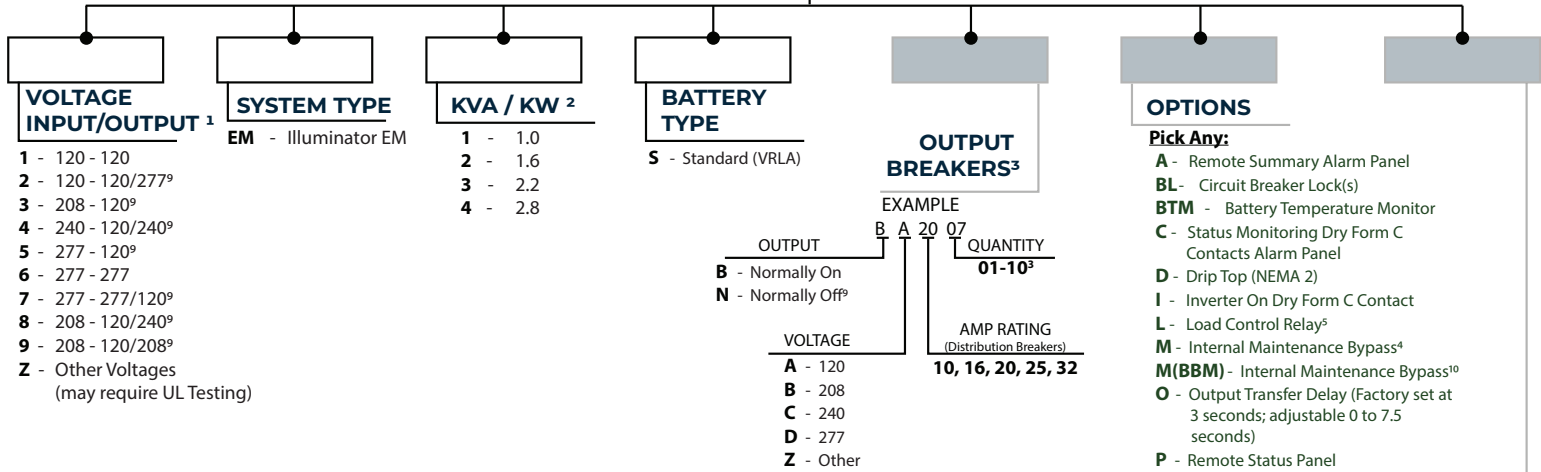

1. Only single phase voltages available.
2. KVA = KW
3. Unless output circuit breakers are specified, a single output breaker will be supplied with each unit and the current rating will vary based on the output power and voltage rating of the unit. Maximum specified output breakers available: 10 unsupervised (1-pole), 6 supervised (1-pole). A 2-pole breaker occupies 2 positions.
4. Maintenance bypass switch is a "make before break".
5. Contact factory for load control applications.
6. One year warranty is standard.
7. 15 minute retransfer time delay of normally off circuit after return of utility.
8. Circuit breaker protection provided.
9. Enclosure height may increase. Contact factory.
10. Maintenance Bypass is "break before make".
11. Remote Status Panel requires "C" Option (Status Monitoring Dry Form C Contacts Alarm Panel).

ACCESSORIES

EMBP - External Maintenance Bypass Switch ^{A,9}

SPARES - Spare Fuses & Circuit Boards

SPAREF - Spare Fuse Kit

A) Cannot purchase External Maintenance Bypass Switch with Internal Output Breaker options.

- Pick 1:**
- BAC - BACnet Communications (MSTP)
 - BIP - BACnet IP
 - IoT - IoT Inverter Connect
 - MIP - Modbus TCP/IP
 - MOD - Modbus RTU
- Mounting Options**
- Pick 1:**
- (BLANK) - Standard Wall
 - F - Floor Mount Bracket (Adds 4" to total system height)
 - W - Wall Mount Brackets
 - Z - Seismic / Raised Floor (Adds 4" to total system height)

= Required feature for part number.

= Optional feature. Not required for part number.

WARRANTY & ONSITE SERVICES⁶

- 2YW - Start Up & Same Day Training
- 2YWT - Start Up, Same Day Training and Full Run Test
- 5YP - 5-Year Preventative Maintenance Plan
- 5YW - 5-Year Extended Electronics Warranty
- TR - Training (If Required On Day)

DIMENSIONS

| Electronics Module | | | | | | | | | Batteries 90 Minutes @ Full Load | | | | |
|--------------------|-----------------------|------------------------|--------------------|-----------------|--------------------|------------------|-----------------|-------------------|----------------------------------|---------------------|---------------|----------------|--------------------------------|
| Model Number | Power Rating (VA / W) | Efficiency (Typical %) | Audible Noise (db) | Heat Loss (BTU) | Cabinet Dimensions | | | | 90 Minutes Batteries (lbs / kg) | Number of Batteries | Voltage (VDC) | Current (amps) | Total System Weight (lbs / kg) |
| | | | | | Width (in / cm) | Height (in / cm) | Depth (in / cm) | Weight (lbs / kg) | | | | | |
| EM-1 | 1000 | 98 | 45 | 70 | 24.25 / 61.6 | 27.5 / 69.9 | 10.5 / 26.67 | 121 / 55 | 160 / 73 | 4 | 48 | 26 | 281 / 128 |
| EM-2 | 1600 | 98 | 45 | 110 | 24.25 / 61.6 | 43.25 / 109.86 | 10.5 / 26.67 | 165 / 75 | 240 / 109 | 6 | 72 | 27 | 405 / 184 |
| EM-3 | 2200 | 98 | 45 | 150 | 24.25 / 61.6 | 43.25 / 109.86 | 10.5 / 26.67 | 174 / 79 | 320 / 146 | 8 | 96 | 27 | 494 / 225 |
| EM-4 | 2800 | 98 | 45 | 190 | 24.25 / 61.6 | 55 / 139.7 | 10.5 / 26.67 | 203 / 92 | 400 / 182 | 10 | 120 | 27 | 603 / 274 |

