

UNIVERSAL MICRO INVERTER
PURE SINUSOIDAL AC OUTPUT
OUTPUT VOLTAGE AUTO SETTING EQUAL TO INPUT VOLTAGE
AUTO DIMMING (1-10V) OF CONNECTED LOAD



IMPORTANT SAFEGUARDS

WHEN USING ELECTRICAL EQUIPMENT, BASIC SAFETY PRECAUTIONS SHOULD ALWAYS BE FOLLOWED, INCLUDING THE FOLLOWING

READ AND FOLLOW ALL SAFETY INSTRUCTIONS

1. To prevent electric shock, switch off the mains power until installation is complete and AC input power is supplied to this product.
2. This product requires an unswitched AC power supply of 120-277V, 50/60Hz.
3. Make sure all connections are in accordance with the National or Canadian Electrical code and any local regulations.
4. To reduce the risk of electrical shock, disconnect both normal power, emergency power supplies and unit connector of this product before servicing.
5. For emergency operation of LED, incandescent, fluorescent fixtures and screw-base lamps.
6. Use this product in 0°C minimum, 50°C maximum ambient temperatures (Ta). To ensure the emergency operating time over 90 minutes, the output emergency power of LVU-2/5 should be maximum of 25W for the LVU-2 and 50W for the LVU-5.
7. Use with grounded, UL Listed, damp location rated fixtures. Do not use outdoors. Do not mount it near gas, heaters, air outlets or other hazardous locations.
8. Do not attempt to service the batteries. A sealed, non-maintenance battery is used that is not field replaceable. Contact the manufacturer for information or service.
9. The use of accessory equipment not recommended by the manufacturer may cause an unsafe condition and void warranty.
10. Do not use this product for other than intended use.
11. Installation and service should be performed by qualified service personnel.
12. This product should be mounted in locations and at heights where it will not readily be subjected to tampering by unauthorized personnel.



**THIS PRODUCT CONTAINS A RECHARGEABLE NICKEL-CADMIUM BATTERY.
THE BATTERY MUST BE RECYCLED OR DISPOSED OF PROPERLY.**

INSTALLATION



CAUTION: MAKE CERTAIN THE AC POWER IS OFF AND THE LVU-2/5 UNIT CONNECTOR IS DISCONNECTED UNTIL THE INSTALLATION IS COMPLETE.

1. SPECIFICATION OF LVU-2/5

Voltage		Output power	
Input	Output	LVU-2	LVU-5
120V/60Hz	120V/60Hz	25W	50W
208V/60Hz	208V/60Hz		
277V/60Hz	277V/60Hz		

2. INSTALLING THE LVU-2/5

The LVU-2/5 can be mounted inside or outside (nearby or on top of) the luminaire.

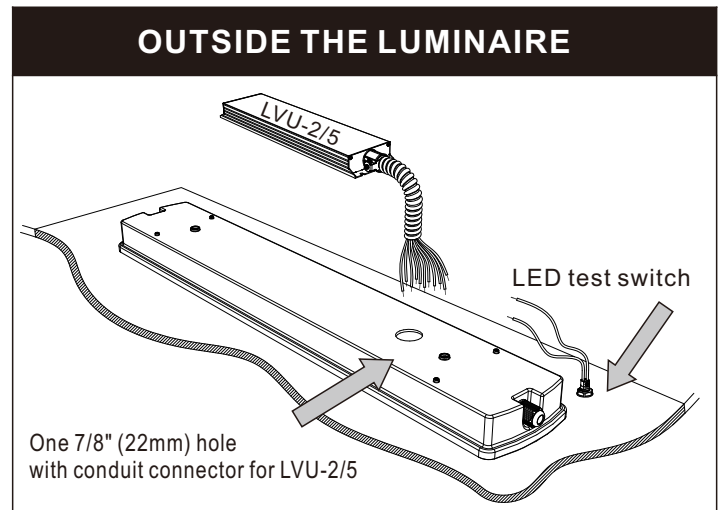
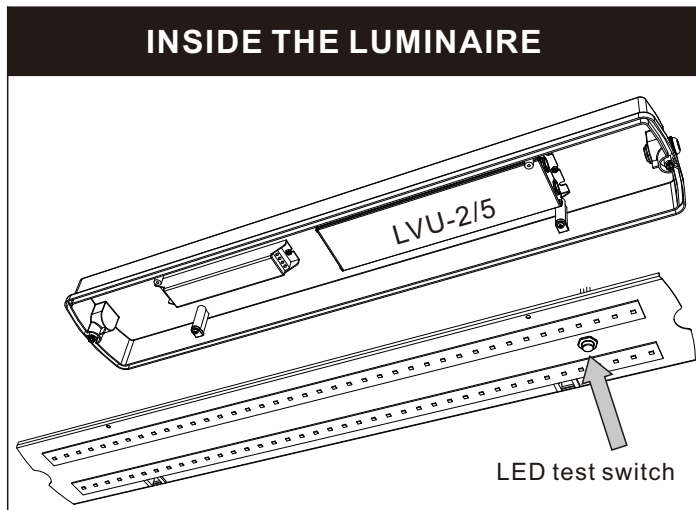

3. INSTALLING THE LED TEST SWITCH (LTS)

Select a convenient location for the LTS so that it can be seen after installation. Drill a 1/2" (12 mm) hole for mounting the LTS. Connect the wires from LTS to the LVU-2/5 model according to the wiring diagram on page 3.

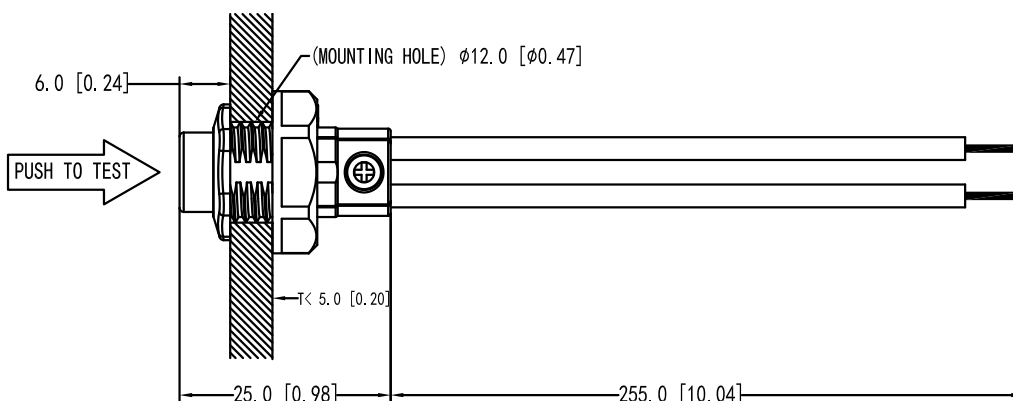

WIRING



CAUTION: DO NOT MATE UNIT CONNECTOR UNTIL INSTALLATION IS COMPLETE AND AC POWER IS SUPPLIED.

1. The LVU-2/5 requires an unswitched AC power supply of 120-277 volt, 50/60Hz.
2. For all loads connect hot wire to black.
3. For Normally On Loads-Connect Hot wire to Yellow. For Normally Off Loads-Yellow wire is not Connected. Switched Loads-Connect switch to Yellow wire.
4. Refer to the wiring diagrams below. Make connections in the following order ①②③④⑤⑥⑦
5. Consult the factory for other wiring diagram.

WIRING DIAGRAM FOR 1-10V DIMMABLE EMERGENCY LIGHTING SYSTEM

ANY QUANTITY

TOTAL NORMAL POWER 75W DIMMED TO 25W (LVU-2)
150W DIMMED TO 50W (LVU-5)

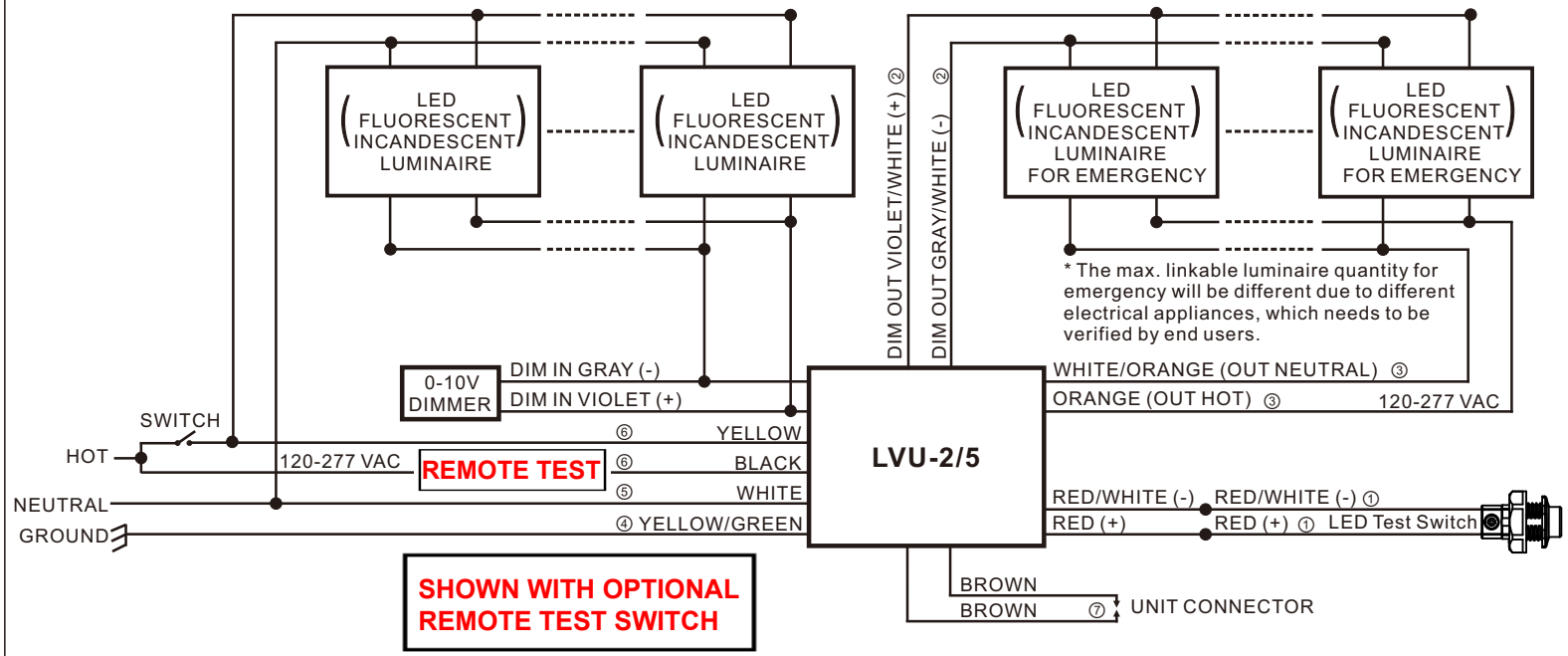

WIRING DIAGRAM FOR NON-DIMMABLE EMERGENCY LIGHTING SYSTEM

ANY QUANTITY

TOTAL POWER LVU-2=25W
LVU-5=50W

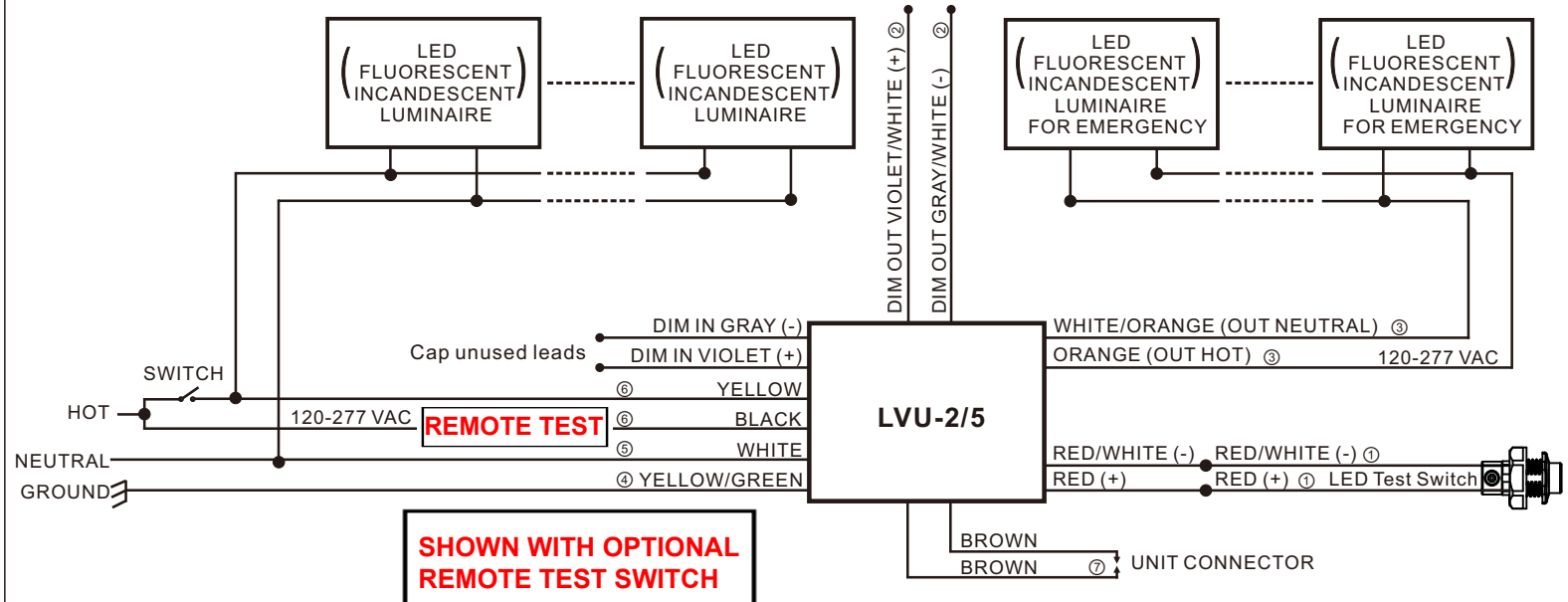

OPERATION / TESTING / MAINTENANCE

OPERATION

When AC power is applied, the LED test switch (LTS) is illuminated, indicating that the batteries are being charged. When AC power fails, the LVU-2/5 automatically switches to emergency (battery) power, which can be maintained for >90 minutes, operating the loads specified emergency power level. The LTS is switched off. When AC power is restored, the LVU-2/5 switches the system back to normal mode and resumes battery charging. The charging time for the full discharged battery is 24 Hours.

TESTING AND MAINTENANCE

Periodic tests are recommended to ensure the system is functioning normally:

1. Visually inspect the LTS monthly. It should be illuminated when AC power is applied.
2. Conduct a 30 second discharge test by switching off the mains power every month.
3. Conduct a 90 minute discharge test once per year. The loads should be illuminated at least 90 minutes.

AUTO TEST

The LVU-2/5 series has integrated Auto Test functions as follows:

1. Instant Auto Test

When the system is connected and powered on, the LVU-2/5 model will Auto Test to verify proper connection of LED load and connection/charging of battery pack. In case of LED load or Battery pack problem, the LTS will flash. When the abnormal condition is corrected, the LTS will stop flashing.

2. Preprogrammed Auto Test

1) The initial monthly Auto Test begins 24 hours to 7 days after initial power up; monthly Auto Tests repeat once every 30 days.

2) Annual Auto Tests repeat every 52 weeks after initial power up.

- Monthly Auto Test

Monthly Auto Test is executed every 30 days, testing:

- (a) Transfer from normal to emergency mode, and the reverse;
- (b) Battery charging in normal mode and discharging in emergency mode;

Test time is about 30 seconds.

- Annual Auto Test

Annual Auto Test is executed every 52 weeks after 24 hours full charging, testing:

- (a) Transfer from normal to emergency mode, and the reverse;
- (b) Emergency operation meets 90 minutes minimum; And battery voltage after 90 minutes emergency operation is equal or higher than 87.5% of initial voltage.

3) During Auto Test, in case of power failure and cannot be on till the auto test completes, the Auto Test will be executed again 24 hours after the power has been resumed.

4) If the emergency mode causes the battery discharged completely under the power-off condition, the Preprogrammed Auto Test will be reset after power has been resumed.

MANUAL TEST

- Press LTS one time to simulate emergency mode.

- Press LTS 2 times within 5 seconds to initiate monthly test. Upon completion of this test, the Monthly auto-test counter is set to repeat after 30 days.

- Press LTS 3 times within 5 seconds to initiate annual test. Upon completion of this test, the Annual auto-test counter is set to repeat after 52 weeks.

- During the manual test, press and hold the LTS for longer than 3 seconds or press LTS 3 times to terminate the test. (The next-occurring preprogrammed Auto Tests – Monthly and Annual -- will remain scheduled).

LED test switch (LTS) INDICATION

- LTS slow flash: In charging

- LTS on: Normal

- LTS off: Power failure

- LTS gradual change: In testing mode

- LTS quick flickering: Abnormal condition - Corrective required