

MODEL RLY-SW-2 INSTALLATION INSTRUCTIONS

IMPORTANT SAFEGUARDS

WHEN USING ELECTRICAL EQUIPMENT, BASIC SAFETY PRECAUTIONS SHOULD ALWAYS BE FOLLOWED. THESE INCLUDE:

READ AND FOLLOW ALL SAFETY INSTRUCTIONS

1. This product can be used with LED, ballast, tungsten, and general use loads.
2. Make sure all connections are in accordance with the National Electrical Code and local regulations.
3. To reduce the risk of electric shock, disconnect both normal and emergency power supplies before servicing.
4. This product is intended to be used to control indoor and outdoor located loads.
5. An unswitched AC power source is required (120-240VAC/ 277VAC).
6. Do not install near gas or electric heaters.
7. Do not attempt to service a sealed Emergency Power Control. If it is malfunctioning, return to the manufacturer, Myers Emergency Power Systems, LLC, 44 S. Commerce Way, Bethlehem, PA 18017.
8. The use of accessory equipment is not recommended by the manufacturer and may cause an unsafe condition.
9. Do not use this product for other than intended use.
10. Servicing should be performed by qualified service personnel.
11. Equipment should be mounted in locations and at heights where it will not readily be subjected to tampering by unauthorized personnel.

SAVE THESE INSTRUCTIONS

5-Year Limited Warranty

Myers Emergency Power Systems, LLC warrants to the original purchaser/users for the published warranty period from the date of shipment that should Myers EPS equipment prove defective by reason of improper workmanship or material, Myers EPS will repair or replace the same equipment without charge. This warranty does not cover defects or malfunctions arising from improper installation, operation, repair or neglect, accident, or abuse. Myers EPS will honor its warranty provided the equipment has not been physically damaged or improperly installed or connected. To obtain warranty/repair within the warranty period, the defective product should be shipped freight prepaid to the address at the bottom of this document. To the extent permitted by applicable law, all warranties extending beyond repair or replacement as described above are disclaimed. This includes implied warranties of merchantability and fitness for a particular purpose. Where applicable law prohibits disclaimers or the implied warranties of merchantability and fitness, those warranties are limited to 12 months from date of shipment. Myers EPS provides a 90-day money back guarantee if equipment does not perform in accordance with the Myers EPS published specifications. The liability of Myers EPS and its agents under all warranties is limited to repair and replacement as described herein and under no circumstances shall there be liability for any other kind of loss, damage, or labor—either consequential or for injury to a person or property or otherwise.

Electrical Specifications

120-240/277V Sensing Input
20 Amp Ballast Load Rating (120-277V)
20 Amp General Use Rating (120-277V)
1200W Incandescent Load Rating (120V)
1500W Incandescent Load Rating (277V)
Normally Closed Output Contact
UL924 Listed (U.S. UL/cUL)



Mechanical Specifications

Mounts in 4-11/16" Junction Box with Extension Box
Use single gang plaster ring or blank cover
Suitable for installation in the plenum
Tested to UL2043 UL94-5VA Plastic Flame Rating
Shipping Weight: 8 oz Color : White
Temperature: -10°C-60°C (14°F - 140°F)
Flush Mounted Size: 4-1/2" x 2-3/4" x 1/4"
Body Size: 2-7/8" x 1-3/4" x 1-7/32"



Myers Emergency Power Systems, LLC
44 S. Commerce Way
Bethlehem PA 18017
610-868-3500 | www.MyersEPS.com

Application

In the past, all emergency lights were left on 24 hours a day to meet safety codes. Now you can specify and install a **UL924 Listed Emergency Power Control, RLY-SW-2**, which converts up to 20A of normal light fixtures to approved emergency lights. During normal operation, the RLY-SW-2 dims designated emergency lights using the same controls as normal (non-emergency) lights. During a utility power interruption, the RLY-SW-2 turns designated emergency lights on, regardless of switch position. **The RLY-SW-2 is intended for use with such switching controls as wall switches, occupancy sensors, relay panels, and ON/OFF room controllers.**

Which Model Do You Need?

For	Choose Model
0-10V, EcoSystem, or DALI Dimmable Loads	RLY-DIM-2D
Line Voltage Dimmable Loads	RLY-DIM-D

Patented Automatic Diagnostic

When the room switch is turned off, RLY-SW-2 tests itself for 2.5 seconds, testing that an emergency power source is available and that the RLY-SW-2, ballast, and lamp(s) are functioning correctly. This feature eliminates the need for manual monthly testing and is approved for this purpose. This allows installation in any location because its test switch does not need to be accessible. This feature can be disabled in the field by cutting the blue jumper.

Inverter or Fire Alarm Remote Test Switch

Some applications demand that emergency lighting be activated upon fire alarm, security alarm, or remote test switch activation. The RLY-SW-2 is equipped with a low voltage override input (red jumper). Contact your local Myers Emergency Power Systems Sales Representative for more details.

This device can be remotely tested by applying 24VDC to the red jumper wire. Applications include fire alarm override and inverter monthly testing. Please contact Myers Emergency Power Systems for application and wiring details.

Mounting

The RLY-SW-2 features a unique universal mounting, which is a single enclosure design that allows flush, fixture, plenum, or panel mounting, as shown below.

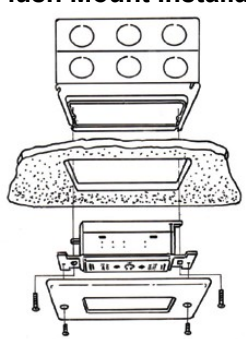
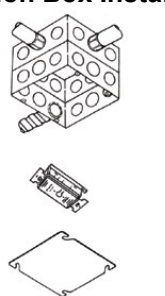
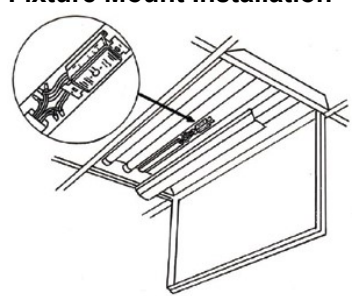
Flush Mount Installation	Junction Box Installation	Fixture Mount Installation
 <p>Recommended box size 4-11/16" with extension (total depth 4" minimum)</p>	 <p>Recommended box size 4-11/16" with extension (total depth 4" minimum). Tested to UL 2043: suitable for installation in the plenum.</p>	 <p>Confirm body size (2-7/8" x 1-3/4" x 17/32") will fit in fixture ballast channel prior to installation.</p>

Installation

In order to install the RLY-SW-2 in accordance with national/local code requirements, a qualified electrician should review and understand the installation instructions: Check voltage and current requirements. Verify and lock out circuit breakers on both regular (utility) power and 24 hours emergency generator or inverter circuit. Install a self-adhesive 2" x 3" caution label in each fixture or load controlled by an RLY-SW-2 indicating that the load is supplied from 2 different power sources: normal and emergency. Review wiring diagram and connect wires, one at a time, in accordance with the numeric identification.

In order to provide a safe light level, when regular power is interrupted, it is recommended that a minimum 5000 lumen are controlled by a 24 hour emergency circuit and are spaced no farther than 24' in any direction from each other in a normal 9' white ceiling environment.

Initial Testing and Troubleshooting

In a new installation, where hundreds of devices may be used, each having as many as 14 wires to be correctly connected, it is important that a fast, convenient method is used to check connections. In order to test that the wires are connected correctly, without any inconvenience to occupants, do not turn off regular (utility) power until you have checked each device as follows:

1. Check that regular branch circuit breaker is connected and utility power is available. The green LED should be lit. If the green LED is not lit, check connections and continuity to branch circuit breaker.
2. Check that the emergency branch circuit breaker is connected and emergency power is available. The red LED should be lit. If the red LED is not lit, check the connections and continuity to the branch circuit breaker.
3. Normal Operation Test: Turn the room switch or other control device to the "ON" position. Normal and emergency lights should turn on. Turn the room switch or control to the "OFF" position. Normal lights should turn off immediately. If the blue loop is connected, emergency lights should stay on for at least 2.5 seconds. If the blue jumper is cut and capped, emergency lights should turn off immediately.
4. Emergency Operation Test: Press and hold the test button. Emergency lights should illuminate at full brightness until the test button is released.

Maintenance

No maintenance is required to keep the RLY-SW-2 functional. However, regular testing should be performed when the lamps, ballasts, LED drivers, or arrays have been replaced or when remodeling has taken place.

Single Line Drawings

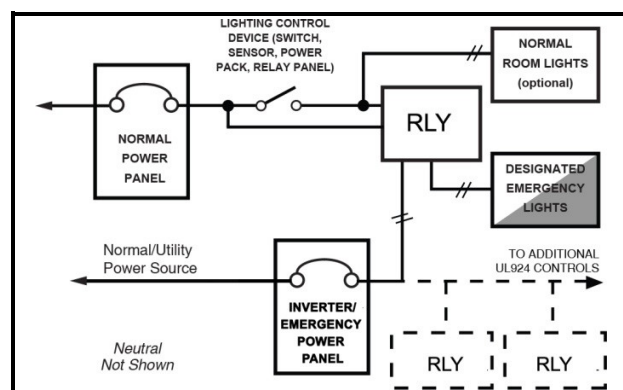
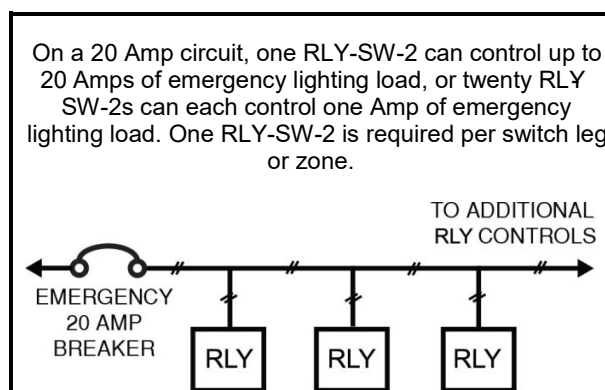

Model RLY-SW Wiring Diagrams

Wiring Diagram 1 (Suggested)

A common switch controls both normal and emergency lighting in a space. Upon loss of normal power, the emergency lighting comes on regardless of switch position.

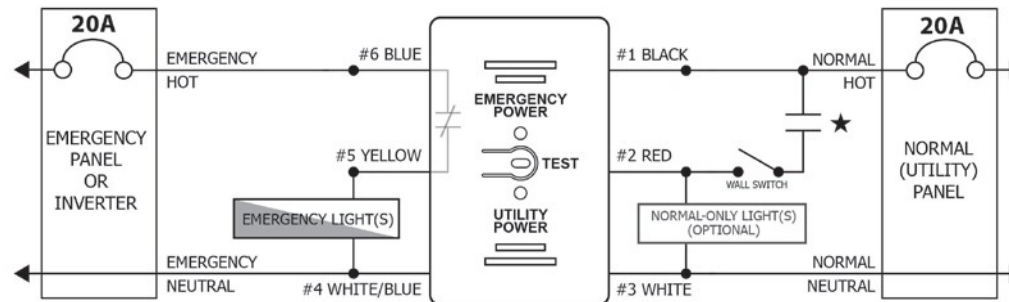

Wiring Diagram 2 (Shunt)

A dedicated switch controls emergency lighting in a space. Upon loss of normal power, the emergency lighting comes on regardless of switch position.

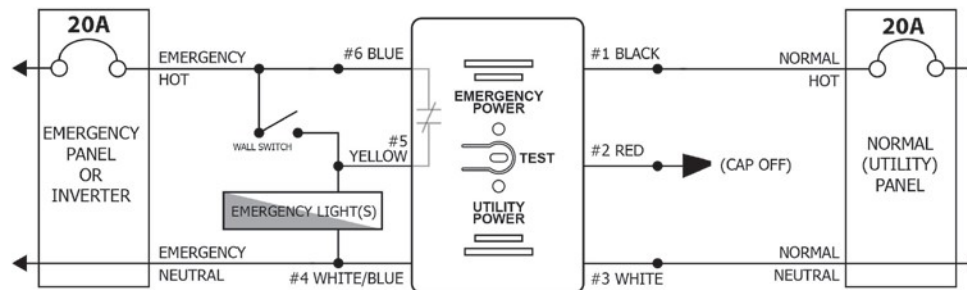

Frequently Asked Questions

Do I need a separate normal and emergency ballast/driver?	NO , the emergency light only needs a single ballast/driver. The Normal-Only light(s) shown are separate light fixtures that you want to control with the same switch, but which do not serve as emergency lighting during a power interruption.
Can I use the RLY-SW-2 with 3-way switches?	YES , replace the single pole wall switch above with your 3-way switches.
Can I use the RLY-SW-2 with A/B switching?	YES , but you need a separate RLY-DIM-2D for each switch leg (i.e. two RLY-DIM-2Ds for A/B switching). If you are using a special step-dim ballast/driver please consult Myers Emergency Power Systems for compatibility information.
Can I use the RLY-SW-2 with dimmers?	NO , use model RLY-DIM-2D for 0-10V dimmers and RLY-DIM-D for line voltage dimmers.