

LED-BP-SLIM Series

Field & Factory Installable Emergency LED Battery Pack (4.5W to 18W)

FLEXIBLE CONDUIT MODELS



LED-BP-SLIM-4.5W



LED-BP-SLIM-9W



LED-BP-SLIM-13.5W



LED-BP-SLIM-18W

PUSH IN TERMINAL BLOCK MODELS



LED-BP-SLIM-4.5W-TB



LED-BP-SLIM-9W-TB



LED-BP-SLIM-13.5W-TB



LED-BP-SLIM-18W-TB

APPLICATION

The LED-BP-SLIM Series battery packs allow users to convert normal LED luminaires into approved emergency lighting luminaires. Featuring a slim profile, the units can be mounted inside or outside of the luminaire.

During emergency operation, LED-BP-SLIM automatically transfers to battery power. The automatic voltage detection circuit matches the output voltage to your specific LED fixture, and runs it at constant power/light output for a minimum of 90 minutes. When the AC power is restored, the emergency LED-BP-SLIM Series switches the system back to normal mode of operation and resumes battery charging.

FEATURES

- UL924 Listed
- Converts LED luminaires into approved emergency lights for 90 minutes
- Constant power output with automatic overload and low battery protection
- Automatic Voltage Detection: can be used with LED drivers/luminaires operating from 5-300VDC
- 120-277VAC Universal Input
- LED Test Switch 
- Li-Ion batteries provide long life and are maintenance-free
- 5-Year Warranty
- Self-diagnostics
- Suitable for use in dry or damp locations.
- Available in 4.5W-18W sizes (Approximately 450-1800 lumen output)
- Can be mounted inside or outside of the luminaire
- Unique feature: conduit version may be converted to TB version if installation requirements change.

SINGLE LINE DRAWING

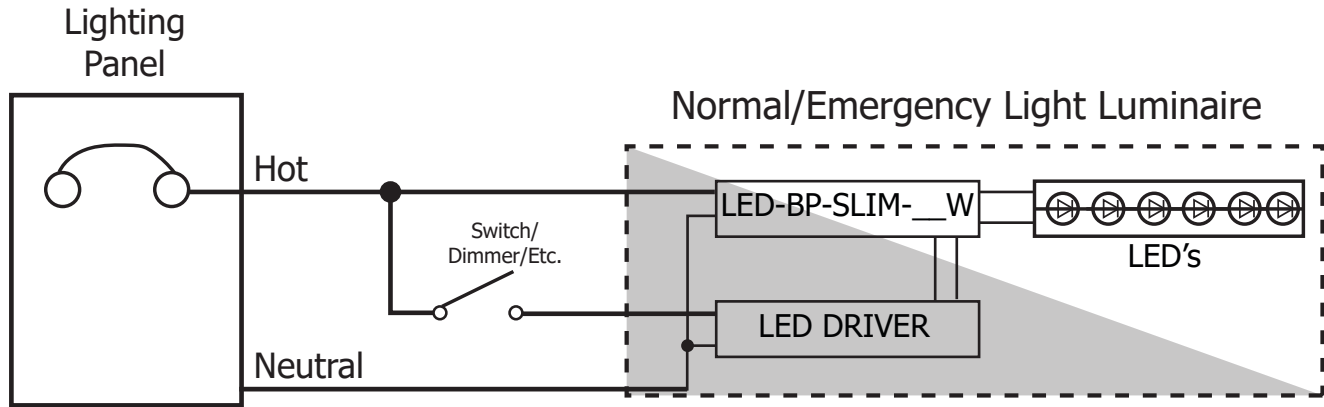

SPECIFICATIONS

For Flexible Conduit Models :

MODEL NO	INPUT VOLTAGE	OUTPUT VOLTAGE (VDC)	OUTPUT POWER (WATTS)	DIMENSIONS L x W x H (INCHES)	TEMPERATURE (°C)	WARRANTY
LED-BP-SLIM-4.5W	120/277V AC 50/60 Hz	5-200	4.5	10.16 x 1.18 x 0.87	0~55	5-year replacement warranty
LED-BP-SLIM-9W	120/277V AC 50/60 Hz	10-300	9	12.52x 1.18 x 0.87	0~55	
LED-BP-SLIM-13.5W	120/277V AC 50/60 Hz	15-300	13.5	15.87x 1.18 x 0.87	0~55	
LED-BP-SLIM-18W	120/277V AC 50/60 Hz	20-300	18	18.43 x 1.18 x 0.87	0~55	

For Push In Terminal Block Models:

MODEL NO	INPUT VOLTAGE	OUTPUT VOLTAGE (VDC)	OUTPUT POWER (WATTS)	DIMENSIONS L x W x H (INCHES)	TEMPERATURE (°C)	WARRANTY
LED-BP-SLIM-4.5W-TB	120/277V AC 50/60 Hz	5-200	4.5	7.87 x 1.18 x 0.87	0~55	5-year replacement warranty
LED-BP-SLIM-9W-TB	120/277V AC 50/60 Hz	10-300	9	10.24 x 1.18 x 0.87	0~55	
LED-BP-SLIM-13.5W-TB	120/277V AC 50/60 Hz	15-300	13.5	13.58 x 1.18 x 0.87	0~55	
LED-BP-SLIM-18W-TB	120/277V AC 50/60 Hz	20-300	18	16.14 x 1.18 x 0.87	0~55	

Note: Cold weather rated battery packs available, contact factory for details.