

Illuminator E-H

Emergency Lighting Inverter System

Single Phase OSHPD Rated Systems 1.5KVA/KW to 16.7KVA/KW
For All Lighting & Motor Loads

Models 6.0KVA to 16.7KVA

Models 1.5KVA to 5.0KVA



STANDARD FEATURES

- Withstand Shaker Table Withstand Tested to SDS Level 2.5
°SDS z/h 1, Importance Factor 1.5
- Tested in Accordance with ICC-ES-AC156
- OSHPD Special Seismic Certification Preapproval # OSP-0305-10
- 98% Efficient (Typical)
- PWM/IGBT Technology
- Micro-Processor Control
- User Programmable with Password Protection
- UL 924 Listed
- Automatic Event, Test and Alarm Log
- RS232 Communications Port
- Input Circuit Breaker
- 2ms Transfer Time

OPTIONAL FEATURES

- Low Audible Noise
- Space-Saving, Single Cabinet Design
- 65kAIC Withstand Rating
- Enhanced Communications
Expanded Building Management Protocols
BACnet or Modbus Communications Interface
- **NEW IoT Connect Cloud Software**
- Internal Maintenance Bypass
- Summary Alarm Dry Form C Contacts
- Status Monitoring Dry Form C Contacts
- Remote Meter Panel
- Output Circuit Breakers
- Factory Startup and Training
- Normally Off Output
- Output Trip Alarms

SPECIFICATIONS

- Input 120 or 277VAC 1 Phase 2 Wire Plus Ground
- Output 120 or 277VAC 1 Phase 2 Wire Plus Ground
- Output Load Power Factor .5 Lag to .5 Lead
- Compatible with all LED Drivers
- Forced Air Cooling Only During Emergency Operation;
No Air Filters Required
- Output Distortion Less than 3% THD for Linear Loads
- Generator Compatibility
- Custom & Mixed Voltages Available
- 90 Minute Runtime Standard;
Extended Runtimes Available upon Request
- Load Reduction Fault
- Meets NFPA-101 for Self-Testing and Self-Diagnostics

ORDERING GUIDE

Example Model Number:
1-EH-4-S-BA2007-T-S-M-2YW

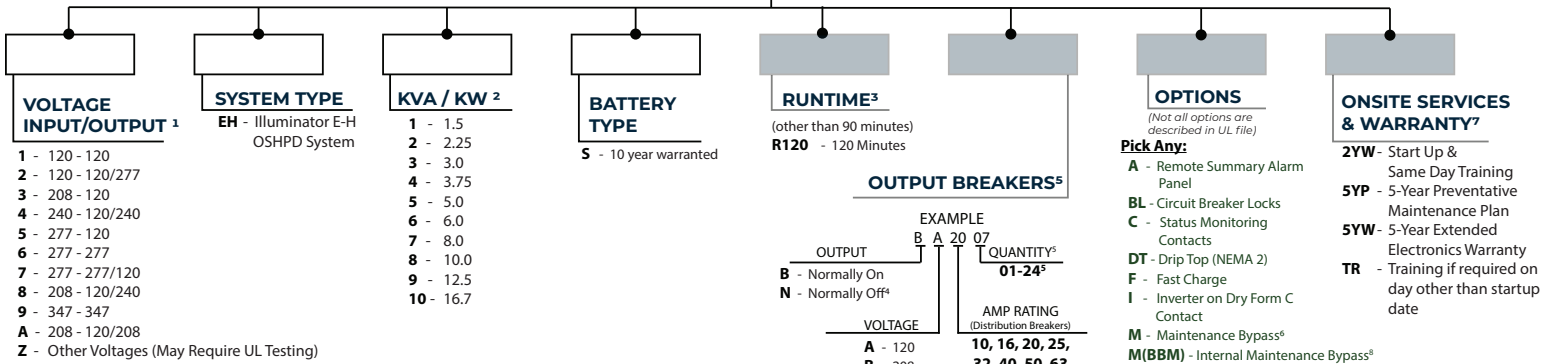

- Only single phase voltages available.
- KVA= KW
- Standard battery runtime is 90 minutes. Contact factory for other runtimes.
- Normally off loads cannot exceed 20% of total KVA rating with any combination of HID loads.
- Maximum output breakers available: 12 unsupervised (1-pole), 8 supervised (1-pole) for 1.5KVA-5KVA; 24 unsupervised (1-pole), 18 supervised (1-pole) for 6KVA-16.7KVA; Breakers provided are 20 Amps unless specified otherwise. A 2-pole breaker occupies 2 positions. Additional output breakers available on 1.5-kva units with optional top mount enclosure. Contact factory for details.
- Maintenance bypass switch is a "make before break".
- One year warranty is standard.
- Maintenance bypass switch is a "break before make".
- 15 minute retransfer time delay of normally off circuit after return of utility. Requires normally off options. Same for Series E.

ACCESSORIES

- EMBP - External Maintenance Bypass Switch^{A,6}
- SPARES - Spare Fuses & Circuit Boards
- SPAREF - Spare Fuse Kit

A) Cannot purchase External Maintenance Bypass Switch with Internal Output Breaker options.

= Required feature for part number.

= Optional feature. Not required for part number.

DIMENSIONS

Electronics Module									Batteries 90 Minutes @ Full Load				
Partial Model Number	Power Rating (KVA / KW)	Efficiency (% Typical)	Audible Noise (db)	Heat Loss (BTU)	Cabinet Dimensions				90 Minutes Batteries (lbs / kg)	Number of Batteries	Voltage (VDC)	Current (amps)	Total System Weight (lbs / kg)
					Width (in / cm)	Height (in / cm)	Depth (in / cm)	Weight (lbs / kg)					
EH-1-S	1.5	98	45	102	36 / 77	47 / 119	25 / 64	215 / 98	296 / 135	4	48	39	511 / 230
EH-2-S	2.25	98	45	153	36 / 77	47 / 119	25 / 64	230 / 105	444 / 200	6	72	38	679 / 306
EH-3-S	3.0	98	45	204	36 / 77	47 / 119	25 / 64	235 / 107	592 / 266	8	96	38	827 / 372
EH-4-S	3.75	98	45	255	36 / 77	47 / 119	25 / 64	240 / 109	740 / 330	10	120	37	980 / 441
EH-5-S	5.0	98	45	340	36 / 77	47 / 119	25 / 64	280 / 128	888 / 400	12	144	40	1168 / 525
EH-6-S	6.0	98	45	408	55 / 122	76 / 193	25 / 64	605 / 272	1110 / 500	15	180	40	1715 / 772
EH-7-S	8.0	98	45	544	55 / 122	76 / 193	25 / 64	640 / 288	1480 / 666	20	240	39	2120 / 954
EH-8-S	10.0	98	45	680	55 / 122	76 / 193	25 / 64	785 / 353	1776 / 800	24	144	82	2561 / 1153
EH-9-S	12.5	98	45	860	55 / 122	76 / 193	25 / 64	805 / 362	2220 / 999	30	180	82	3025 / 1361
EH-10-S	16.7	98	45	1135	55 / 122	76 / 193	25 / 64	885 / 398	2960 / 1332	40	240	80	3845 / 1730

