

EPC-2-D-FM

Emergency Power Control For Switched Loads

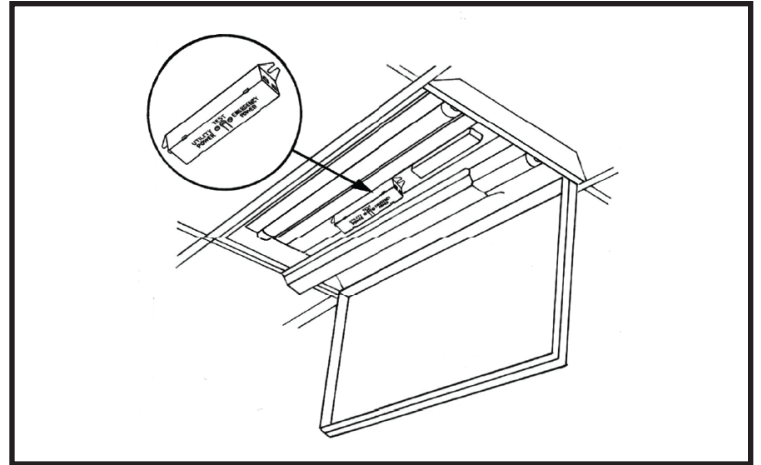
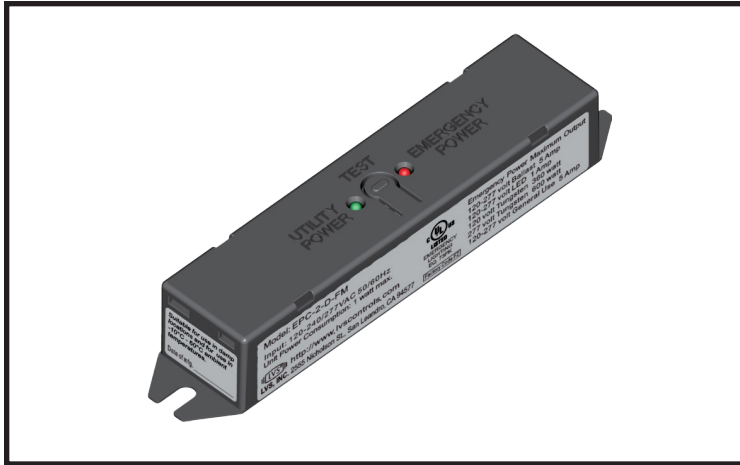

APPLICATION

In the past, emergency lights were kept on 24 hours a day to meet life safety codes. Now, you can use a UL 924 listed Emergency Power Control, Model EPC-2-FM, to convert normal light fixtures into approved emergency lights. The EPC-2-D-FM saves energy and money while ensuring compliance with both life safety and energy codes.

During normal operation, the same dimmer, occupancy sensor, dimming panel, or lighting control can switch and dim normal and emergency fixtures on and off simultaneously.

During a utility power interruption, the EPC-2-D-FM automatically bypasses the normal lighting controls, turning the emergency lights ON at full brightness, regardless of dimmer position.

The EPC-2-D-FM is fixture mounted.

FEATURES

- Unique Patented Automatic Diagnostic: When the room switch is turned off, the EPC-2-D-FM will run a 2.5 self-test routine, verifying that the emergency power source was available and that the EPC-2-D-FM, ballast, and lamp(s) are all functioning correctly. This feature eliminates the need for time-consuming and costly manual monthly testing and is approved for this purpose. This allows the unit to be installed in remote locations, because the unit does not rely on access to its manual test switch.
- Isolated 0-10V relay contact ensures full brightness during utility power interruption, regardless of dimmer model.
- Fire Alarm, Remote Test Option
- Utility & Emergency Power Indicator LED's
- Slim, profile allows mounting in most ballast channels.

SINGLE LINE DRAWING

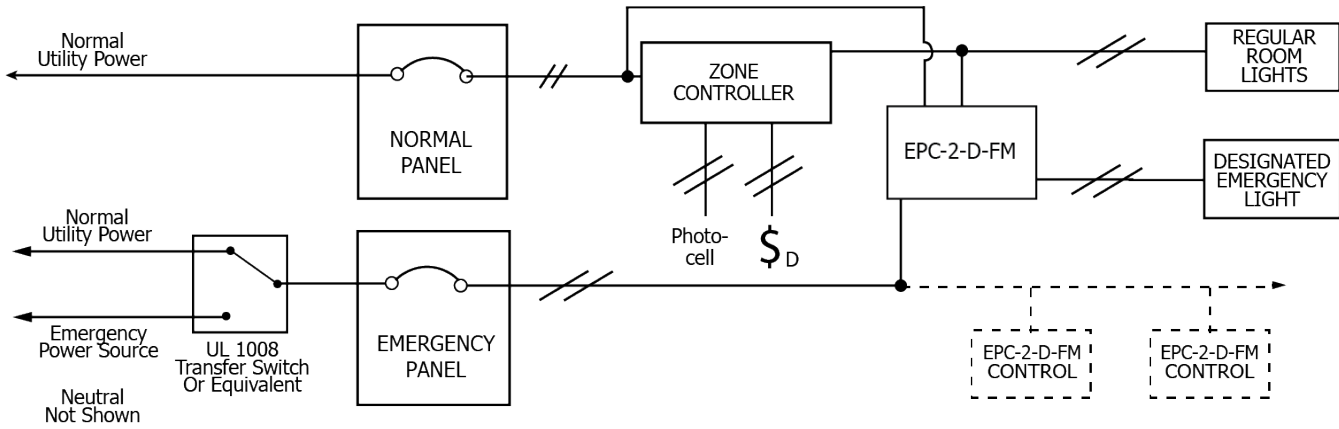

WIRING DIAGRAM

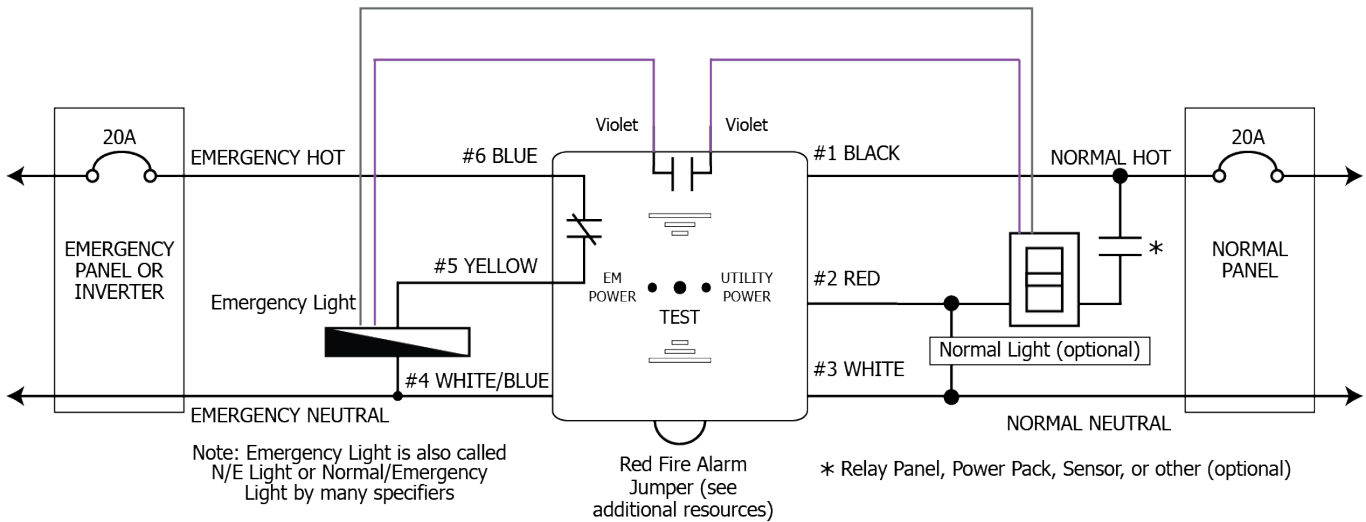

SPECIFICATIONS

ELECTRICAL	MODEL NO.	EPC-2-D-FM
	SENSING INPUT	120V-277V
	LED LOAD RATING	3A (120-277V)
	BALLAST LOAD RATING	5A (120-277V)
	INCANDESCENT LOAD	360W (120V) / 600W (277V)
	WARRANTY	5 Year Replacement Warranty

MECHANICAL	MOUNTING	Fixture Mount, Panel Mount
	RATING	UL94-5VA, Damp Location Rated
	SHIPPING WEIGHT/COLOR	8 oz. / Black
	TEMPERATURE	-40°F - 140°F (-40°C - 60°C)
	BODY SIZE	125mm" x 25.4mm" x 30mm" (L x H x W)