

# ILLUMINATOR HYPERNOVA MODEL U (OUST)

Auxiliary Lighting and Power Inverter



**THREE PHASE SYSTEMS**  
**3kVA/kW to 60kVA/kW**  
Designed with Industry-Leading  
Compact Footprint for Auxiliary Loads



**3.2kVA to 10kVA**

**12.5kVA to 16.7kVA**



**25kVA to 60kVA**

Cabinet depicted is 60kVA. Dimensions shown on chart.

## STANDARD FEATURES

- 98% Efficient Typical
- PWM/IGBT Technology and Micro-Controller
- Internal Maintenance Bypass
- User Programmable with Password Protection
- RS232 Communications Port
- Input Circuit Breaker
- No Break 2ms Transfer Time
- NFPA 101 Self Testing and Data Logging Capable
- Code Compliant : 20 Minute Runtime
- Low Audible Noise (45 dBA @1m)
- Space-Saving Design
- 65 KAIC Withstanding Rating
- NEMA Type 1 Cabinet

## OPTIONAL FEATURES

- Enhanced Communications
  - Expanded Building Management Protocols
  - BACnet or Modbus Communications Interface
  - NEW IoT Connect Cloud Software
- External Maintenance Bypass
- Summary Alarm Dry Form C Contacts
- Internal Output Distribution Circuit Breakers
- Factory Startup and Training
- Normally Off Output
- Output Trip Alarms
- Remote Panels (Meter, Status or Summary Alarm)
- Extended Factory Warranty and Maintenance Contracts

## SPECIFICATIONS

- Input Voltage: 120/208VAC or 277/480 VAC  
3-Phase 4-Wire Plus Ground
- Output Voltage: 120/208VAC or 277/480 VAC  
3-Phase 3 or 4-Wire Plus Ground
- Output Load Power Factor .5 Lag to .5 Lead
- Compatible with All Lighting and Motor Loads
- Forced Air Cooling Only During Emergency Operation;  
No Filters Required
- Output Distortion Less Than 3% THD for Linear Loads
- Compatible With Generators (10x Inverter Size)
- Custom Voltages Available
- 20 Minute Runtime Standard
- Inverter Operating Temperature 32°F to 104°F (0°C to 40°C)
- Battery Operating Temperature 68°F to 86°F (20°C to 30°C)  
per UL 924 Specifications

# ILLUMINATOR HYPERNOVA MODEL U (OUST)

Auxiliary Lighting and Power Inverter

Three Phase Systems 3kVA/kW to 60kVA/kW



## ORDERING GUIDE

EXAMPLE MODEL # 1-U-03-S-R20-BA2007-T-2YW

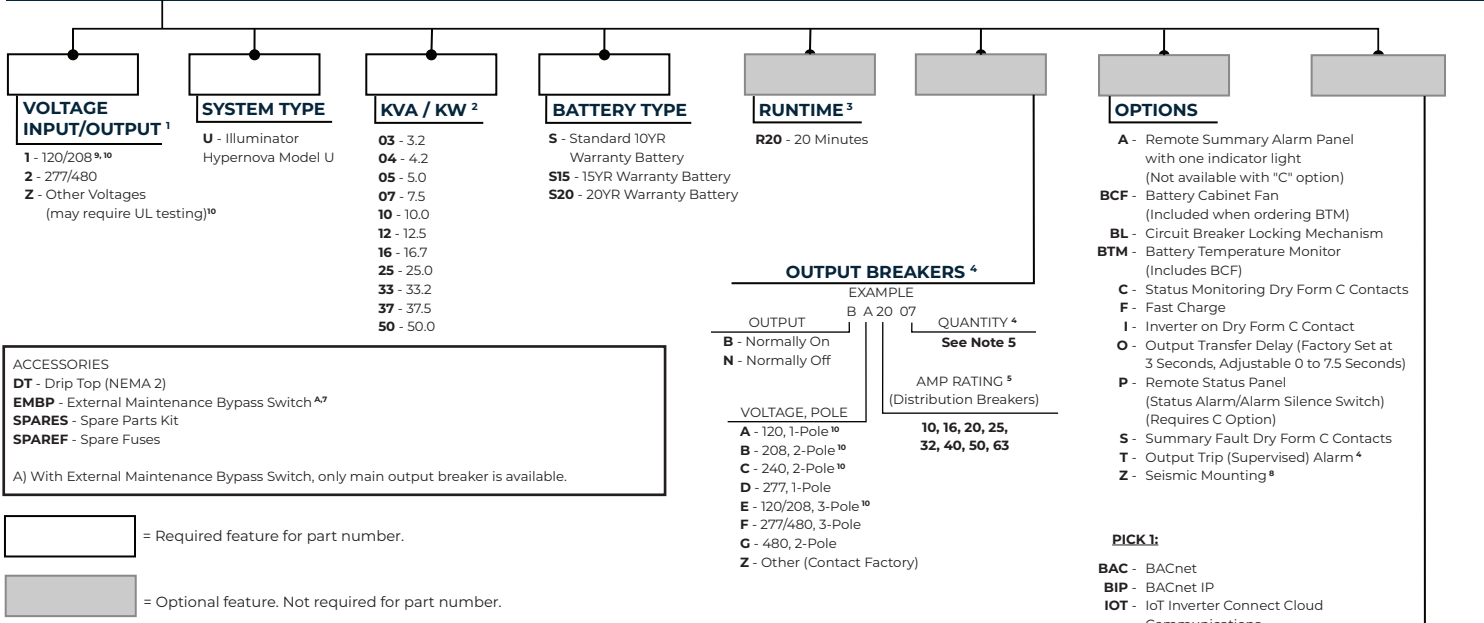

- Standard input voltage is 4-Wire Wye. 3-Wire Delta Input requires external isolation transformer.
- KVA= KW
- Standard battery runtime is 20 minutes. Contact factory for other runtimes.
- Maximum output breakers available:
  - 3.2K-10K - 1 Internal (3-pole); 30 (1-pole) unsupervised or 20 supervised (1-pole) with the addition of a top mount enclosure.
  - 12.5K & 16.7K - 12 (1-pole) unsupervised or 8 (1-pole) supervised and with the addition of a top mount enclosure, an additional 30 (1-pole) unsupervised or 20 (1-pole) supervised.
  - 25K-60K - 24 (1-pole) unsupervised or 16 (1-pole) supervised and with an extra tray an additional 14 (1-pole) unsupervised or 12 (1-pole) supervised.
 Combinations of 1, 2, and 3 pole breakers available (consult factory).
- Higher AMP ratings available - contact factory.
- One year warranty is standard.
- Maintenance bypass switch is a "make before break".
- Anchorage based on calculations - will increase system width. For systems requiring OSHPD/Withstand testing, please see CIII-H.
- 277/480V standard for 60kVA. Contact factory for other voltages.
- Not available on 60kVA.

## DIMENSIONS

Alternate runtimes may affect cabinet size - contact factory.

Electronics Module				Batteries 20 Minutes @ Full Load					Total System						
Partial Model Number	Power Rating (KVA / KW)	Heat Loss (BTU)	Cabinet Dimensions				Voltage (VDC)	Current (Amps)	Battery Cabinet Dimensions			Number of Batteries	Dimensions W X H X D (in)	Weight (lbs)	
			Width (in / cm)	Height (in / cm)	Depth (in / cm)	Weight (lbs)			QTY	Width (in / cm)	Height (in / cm)				Depth (in / cm)
U-03	3.2	341	24 / 61	47 / 119	25 / 64	485	144	41	1	17.5 / 44.5	62 / 157.5	25 / 64	12	41.5 x 62 x 25	1040
U-04	4.2	341	24 / 61	47 / 119	25 / 64	485	144	41	1	17.5 / 44.5	62 / 157.5	25 / 64	12	41.5 x 62 x 25	1040
U-05	5.0	341	24 / 61	47 / 119	25 / 64	485	144	41	1	17.5 / 44.5	62 / 157.5	25 / 64	12	41.5 x 62 x 25	1040
U-07	7.5	512	24 / 61	47 / 119	25 / 64	485	144	61	1	17.5 / 44.5	62 / 157.5	25 / 64	12	41.5 x 62 x 25	1250
U-10	10.0	682	24 / 61	47 / 119	25 / 64	590	144	81	1	17.5 / 44.5	62 / 157.5	25 / 64	12	41.5 x 62 x 25	1355
U-12	12.5	853	30 / 76	47 / 119	25 / 64	640	180	81	1	22.75 / 58	77 / 196	25 / 64	15	53 x 77 x 25	1615
U-16	16.7	1139	30 / 76	47 / 119	25 / 64	640	240	81	1	22.75 / 58	77 / 196	25 / 64	20	53 x 77 x 25	1815
U-25	25.0	1705	37.5 / 95	72 / 182	25 / 64	1150	240	122	2	45.5 / 116	77 / 196	25 / 64	40	83 x 77 x 25	3500
U-33	33.2	2264	37.5 / 95	72 / 182	25 / 64	1150	240	161	2	45.5 / 116	77 / 196	25 / 64	40	83 x 77 x 25	3500
U-37	37.5	2558	37.5 / 95	72 / 182	25 / 64	1360	240	182	3	68.25 / 173.5	77 / 196	25 / 64	60	105.75 x 77 x 25	4885
U-50	50.0	3410	37.5 / 95	72 / 182	25 / 64	1360	240	243	3	68.25 / 173.5	77 / 196	25 / 64	60	105.75 x 77 x 25	4885
U-60	60.0	4092	44 / 112	72 / 182	31 / 79	1460	240	291	4	91 / 232	77 / 196	25 / 64	80	135 x 77 x 31	6160